



- **Compact design, Easy to handle.**
- **Turf Tires**
- **Telescopic Boom as standard.**
- **Kubota Engine**
- **Electrical parking as standard.**
- **Optional Rear Hydraulic Output.**
- **Great maneuverability**
- **Sound alarm**
- **High-flow auxiliary hydraulics**
- **Mini Bobcat plate or Avant Plate**
- **CE, FOPS & ROPS Certified**

Model	SSA1600
Dimension (LxWxH)	3410mm*1510mm*2320mm
Max. reach(boom extended)	3530mm (138.9")
Max. reach(boom retracted)	2908mm (114.5")
Bucket capacity	600L
Rated loading capacity	1600kg (3527 lbs)
Tipping load	2600kg (5732 lbs)
Min. turning radius	1535mm (60.5")
Ground clearance	330mm (12.99")
Turning angle	45 Degree
Speed	16.5 km/h (10.25 mph)
Weight	2300 kg (5070 lbs)
Standard tire	31X15.5-15
Tire pressure	2.8 bar (40 psi)
Oil tank capacity	70L (18.5 gal)
Pressure	200bar (2900 psi)
Working oil flow	82L/min (21.6 gpm)
Tracking oil flow	117L/min (30.9 gpm)
Oil model(mineral oil)	L-HL46
Fuel tank capacity	32L (8.5 gal)
Battery capacity	70Ah
Voltage	12v

Shelter Structures America

405 Via Chico, Suite 1

Palos Verdes Estates, CA 90274

424-254-9172

www.Shelterstructuresamerica.com

sales@wilddogequipment.com

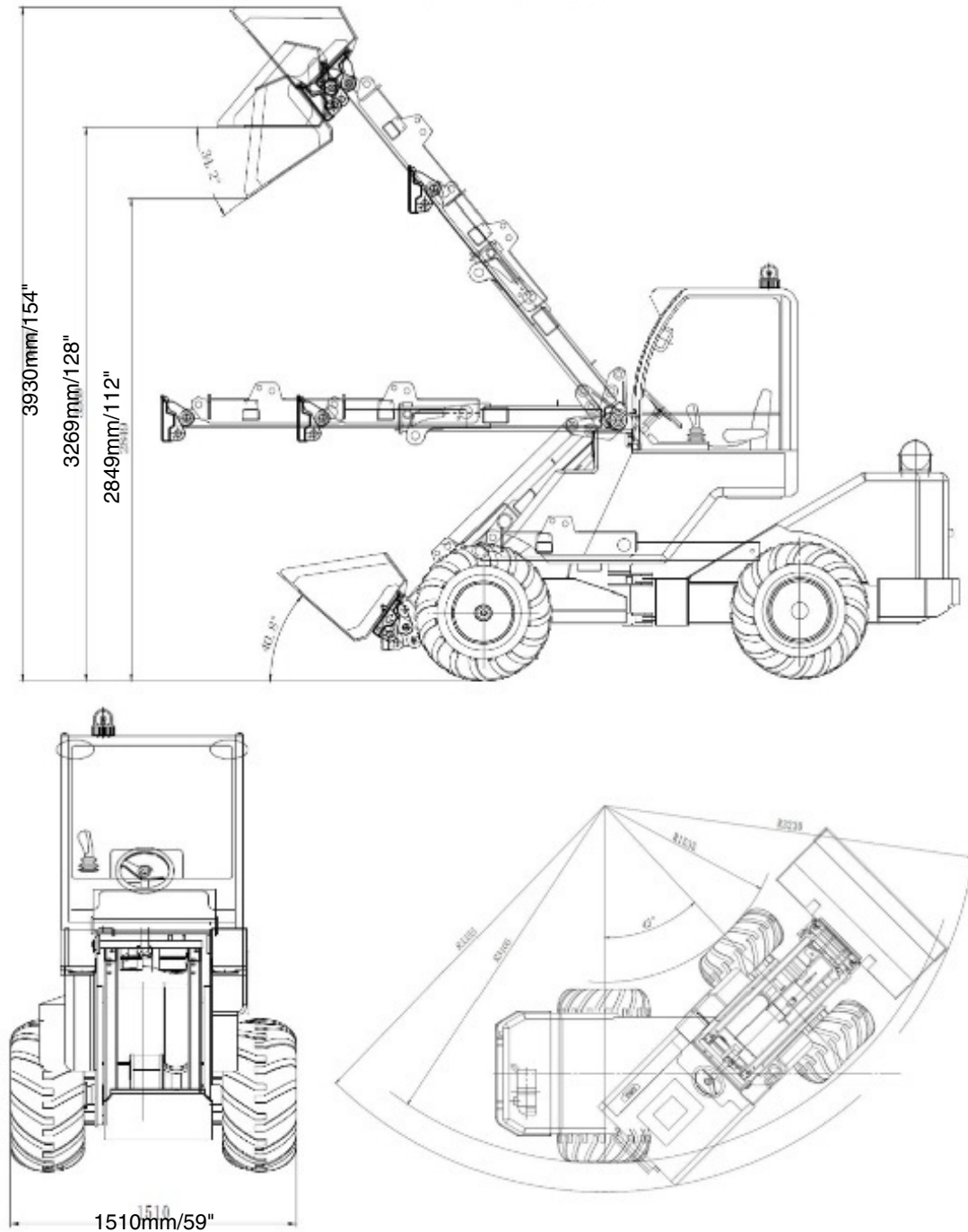

Shelter Structures America
405 Via Chico, Suite 1
Palos Verdes Estates, CA 90274

424-254-9172

www.Shelterstructuresamerica.com

sales@wilddogequipment.com